



Native Grass Hex Shaft Update Kits 705NG and 1005NG Drills

Used with:

- 705NG drills serial number 1948Q and earlier
- 1005NG drills serial number 5533U and earlier

General Information

These instructions explain how to install the Hex Shaft Update Kits. This upgrade is required if any other Native Grass box components are being upgraded from round shaft to hex shaft.

Note: The shaft in this kit is only compatible with $\frac{3}{4}$ in hex shaft paddles and agitators (not included). Any existing round-shaft components will not fit on the new hex shaft.

These instructions apply to:

Option Package	Part Number
705 NG 3/4 HEX SHAFT KIT	202-610A
1005 NG 3/4 HEX SHAFT KIT	202-611A

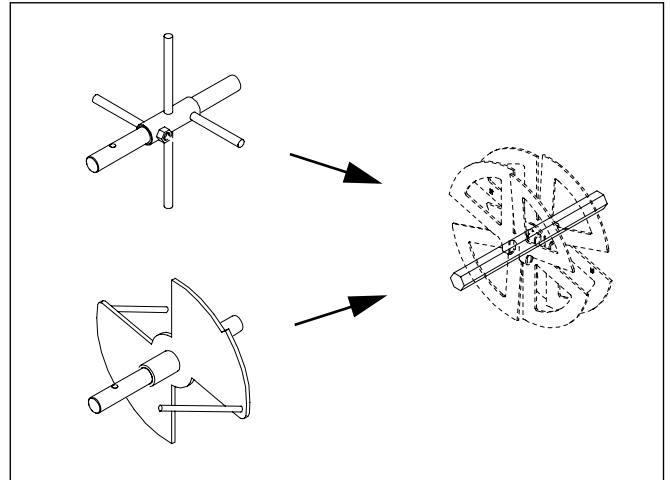

Figure 1
Shaft Upgrade

26283

Before You Start

Each kit converts one drill.

For each kit, inventory the contents per the “**Parts Lists**” on page 7.

Review the instructions, to make sure the steps are understood and what tools are expected.

Have the following items at hand:

- Operator’s Manual for your drill
- Updated Parts Manual for your drill
- Basic hand tools

If necessary, move the drill to a dry well-lighted location suitable for disassembly. The drill may be raised or lowered for this work.

1. Empty the Native Grass box.
2. Secure the tractor.

Notations and Conventions

“Left” and “Right” are facing in the direction of machine travel. An orientation rose in the line art illustrations shows the directions of Left, Right, Front, Back, Up, Down.

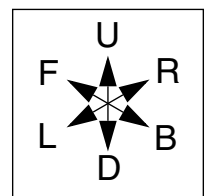

- ① callouts identify components in the currently referenced Figure or Figures.
- ①1 to ②1 callouts reference new parts from the list on page 7. The descriptions match those on the cartons, bags or item tags, as well as your updated Parts Manual.
- ⑤1 to ⑥2 callouts reference affected existing parts. The descriptions match those in your Parts Manual.

Old Component Removal

Dismount Chain

Refer to Figure 2

- On both ends of the Native Grass seed box, flip out the snap fasteners ①. Lift the access panels up and out, and save them.

Refer to Figure 3

- Loosen the idlers ①.
- Remove the chain ② from the drive sprocket ⑤③ and let it hang toward the idlers.

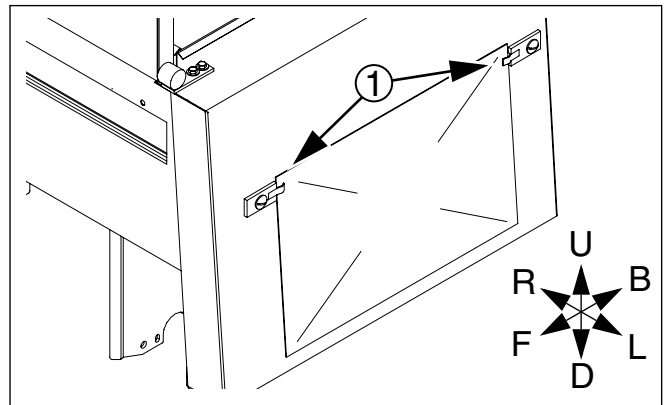

Figure 2
Remove Access Panels

26284

Remove Old Sprocket

Refer to Figure 3

- Remove and save the:
⑥① PIN LINCH 1/4 X 1 3/4 PLT
- Remove the:
⑤③ 24T SPEED CHANGE SPROCKET
It is not re-used.

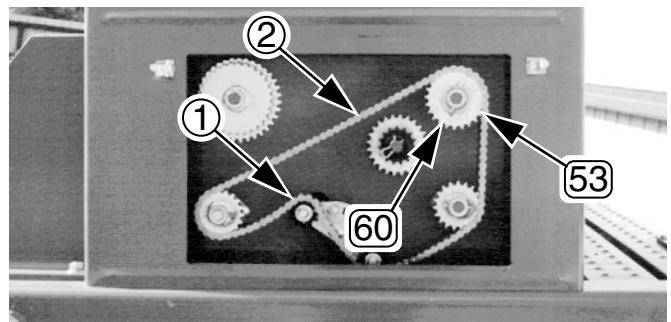

Figure 3
Dismount Chain

18113

Loosen Shaft Components

Loosen Agitator Set Screws

Refer to Figure 4

- At each Native Grass seed cup row, loosen or remove one or two:
⑤⑥ SCREW SET SQ HD 3/8-16 X 3/4CP
from each:
⑤④ AGITATOR WELDMENT 7,7 1/2 & 8
or
⑤⑤ ROD AGITATOR
The set screws are not re-used.

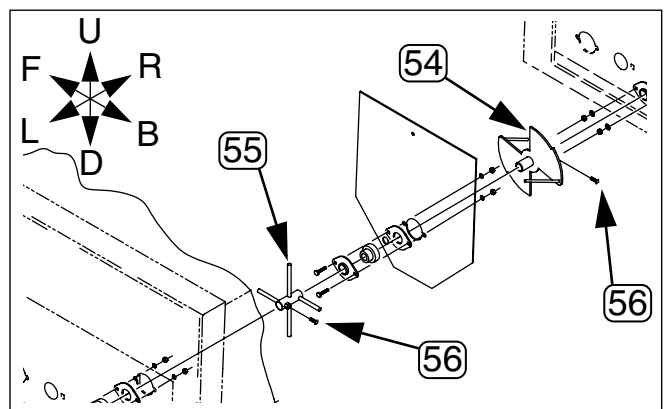

Figure 4
Loosen Old Agitators

26285

Disassemble Flangettes

Refer to Figure 5

9. At the (left) drive end ① of the seed box, at each partition ②, and at the right end ③, remove two each:

⑤⑧ NUT HEX 5/16-18 PLT
 ⑤⑨ WASHER LOCK SPRING 5/16 PLT
 ⑤⑦ HHCS 5/16-18X3/4 GR5
 from the halves of the
 ⑥② FLANGETTE 47 MST

The fasteners are not re-used. The screws are replaced by different size screws in the kit. The flangettes, washers and nuts are the same as in the kit, but the kit includes new parts.

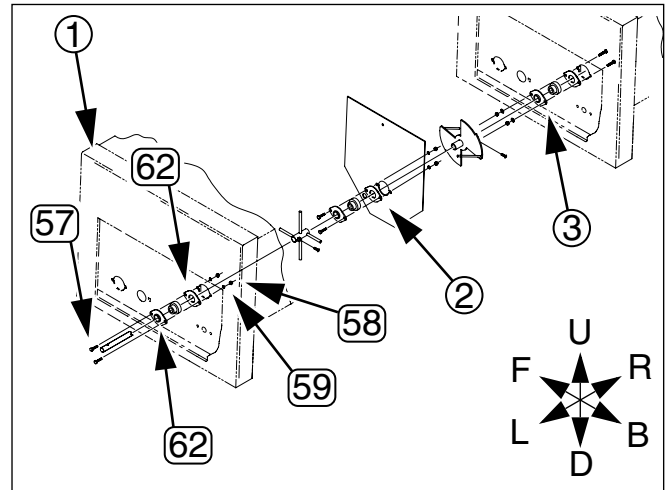

Figure 5
Disassemble Flangettes

26285

Loosen Bearing Set Screws

Refer to Figure 5

10. At the (left) drive end ① of the seed box, at each partition ②, and at the right end ③, loosen or remove two set screws from each:

⑥① BEARING 3/4BORE 47MM SPHERE OD

The set screws are not re-used.

Remove Old Shaft

11. From the drive side, slide the
 ⑤① 7' NATIVE GRASS SHAFT
 or
 ⑤② NATIVE GRASS 114 BOX SHAFT
 out from all loosened components. The shaft is not re-used.
12. Remove shaft components as they clear the end of the shaft. None are re-used.

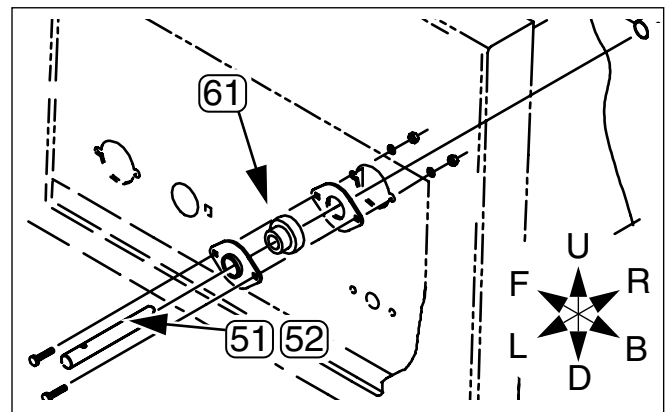

Figure 6
Loosen Old Bearings

26285

Install New Components

Mount Bearings

Refer to Figure 7

Pre-Assemble Bearings

13. Select three (3) sets each new, consisting of one:
 - ②① 822-128C BEARING 3/4HEX B 47MM SPHER OD
 - and two each new:
 - ①⑦ 822-041C FLANGETTE 47 MST
 - ①⑦ 802-282C RHSNB 5/16-18X1 GR5
 - ①⑨ 804-009C WASHER LOCK SPRING 5/16 PLT
 - ①⑧ 803-008C NUT HEX 5/16-18 PLT
14. Place the bearings ②① between a pair of flangette ②⑦ halves, and place per the guidance in the following step.

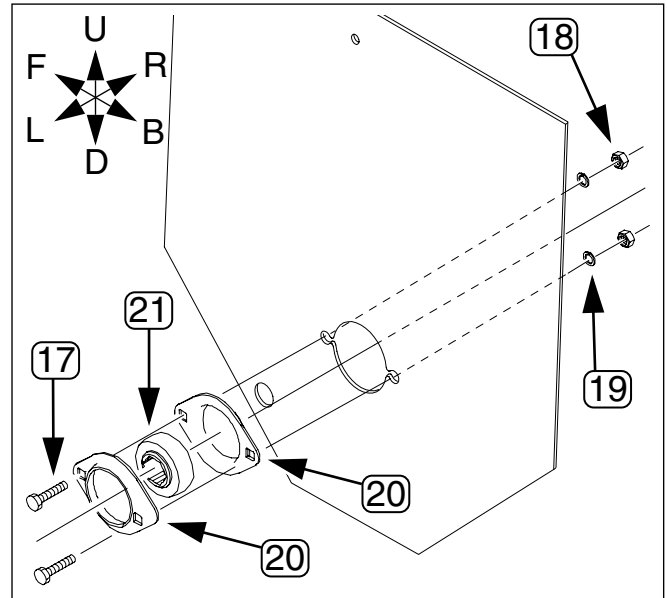

Figure 7
New Bearings

26291

Bearing Mount Locations

Refer to Figure 8

① Box Drive End	Outside box
② Partitions	Whichever side of the partition places the bearing center furthest from both adjacent row unit seed cups.
③ Box Right End	Outside box

Note: By keeping the partition bearings clear of seed cups, you minimize the number of agitators that cannot be installed due to interference.

15. Loosely assemble the bearings at the suggested locations. Insert the screw ①⑦ from the flangette side. Leave the assemblies loose until after shaft insertion.

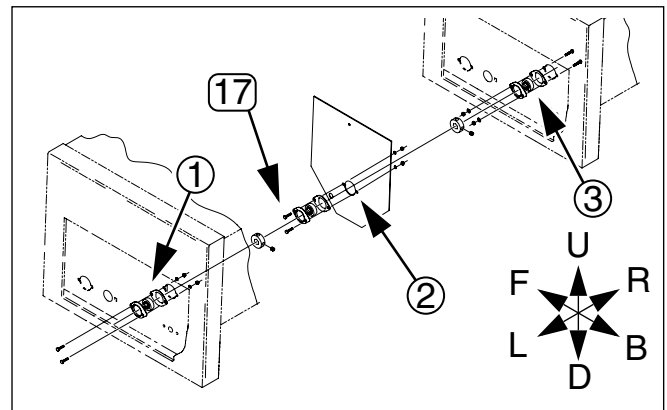

Figure 8
Bearing Placement

26286

Insert Shaft

Refer to Figure 9

16. Select one new:
 - ⑬ 202-223D 705 AGITATOR SHAFT
 - or:
 - ⑭ 202-224D 1005 AGITATOR SHAFT

Note that one end has a hole for the sprocket pin and the other does not.
17. Select two new:
 - ⑫ 118-494D LOCK COLLAR 3/4 HEX BORE
18. Insert the solid (no hole) end of the shaft ⑬/⑭ into the bearing at the drive side of the box.
19. While holding it level, slip a lock collar ⑫ on the solid end of the shaft.
20. Continue inserting the shaft through the new bearing(s) in the partition.
21. Before inserting the shaft through the right end bearing, slip another lock collar ⑫ onto the shaft. Stop the insertion process at this point.
22. Select one new:
 - ⑮ 202-479H AGITATOR SPROCKET WELDMENT
 - and one used:
 - ⑥① PIN LINCH 1/4 X 1 3/4 PLT
23. At the pinned end of the shaft ⑬/⑭, place the sprocket ⑮ on the shaft (raised hub facing out), and insert pin ⑥①. Resume inserting the shaft in the seed box.
24. Insert the solid end of the shaft through the new bearing in the right end of the box.
25. Adjust the position of the shaft ⑬/⑭ until the teeth of the sprocket ⑮ are aligned with the driving, driven and idler sprockets of the Native Grass drive.
26. Select four new:
 - ⑯ 801-035C SCREW SET 5/16-18 SKT KP X 3/8
27. Without disturbing the position of the shaft ⑬/⑭, slide the left lock collar ⑫ against the left end bearing.
28. Insert two set screws ⑯ and secure the collar.
29. Slide the right collar up against the right end bearing. Insert two set screws ⑯ and secure the collar.

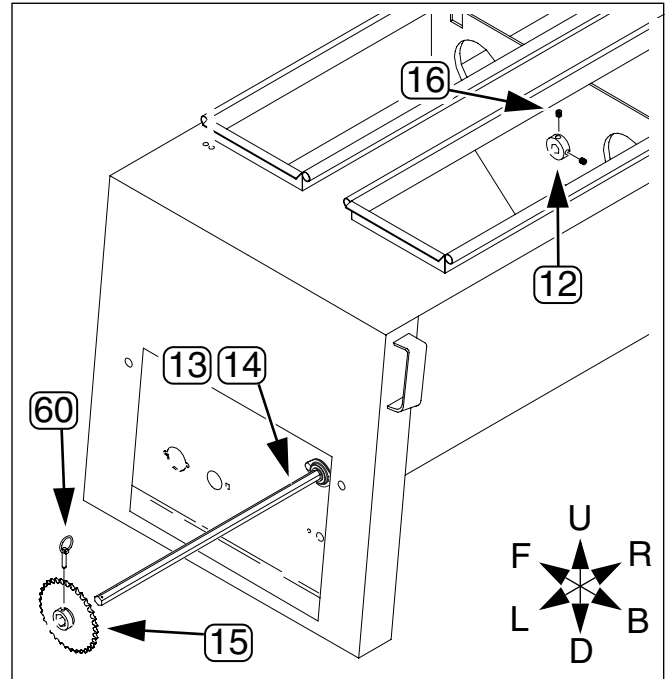

Figure 9
Shaft Insertion

26288

Closeout

30. Gently tighten the bolts of the left side flangette while rotating the new sprocket.
31. Do the same for the right end flangette, and then the partition flangettes.
32. When all are tightened, make sure the shaft rotates freely.
33. Install any new agitators at this time, per the instructions included with the agitator kit. That installation does not require shaft removal.
34. Remount the drive chain, engage the idlers, and adjust for $\frac{1}{2}$ in slack in the longest span.
35. Reinstall access panels and close snaps.

Note: No seed rate adjustments result from this shaft update alone. Other kits that update your drill to Native Grass II may require a new seed rate manual.

Parts Lists

New Parts Included in the 202-610A and -611A Hex Shaft Update Kits:

Callout	Quantity per 202-610A	Quantity per 202-611A	Part Number	Part Description
⑪	1	1	202-612M	This manual
⑫	2	2	118-494D	LOCK COLLAR 3/4 HEX BORE
⑬	1	0	202-223D	705 AGITATOR SHAFT
⑭	0	1	202-224D	1005 AGITATOR SHAFT
⑮	1	1	202-479H	AGITATOR SPROCKET WELDMENT
⑯	4	4	801-035C	SCREW SET 5/16-18 SKT KP X 3/8
⑰	6	8	802-282C	RHSNB 5/16-18X1 GR5
⑱	6	8	803-008C	NUT HEX 5/16-18 PLT
⑲	6	8	804-009C	WASHER LOCK SPRING 5/16 PLT
⑳	6	8	822-041C	FLANGETTE 47 MST
㉑	3	4	822-128C	BEARING 3/4HEX B 47MM SPHER OD

Reference Information

Abbreviations

CP	Cotter Pin
GR5	Grade 5
HHCS	Hex Head Cap Screw (Bolt)
KP	Knurled cup Point
MST	Metric Spherical Two-hole
OD	Outside Diameter
PLT	Plated
RHSNB	Round Head Shank Neck Bolt
SKT	Socket Head
SQ HD	Square Head

Torque Values		
Fastener/Fitting	N-m	Ft-Lbs
⁵ / ₁₆ -18 GR5	24	17

Great Plains Manufacturing, Inc.

Corporate Office: PO Box 5060
Salina, KS 67402-5060 USA