

**PRESS AND CAMBRIDGE ROLLS
FOLDING WING MODELS 4.6 - 8.7M**

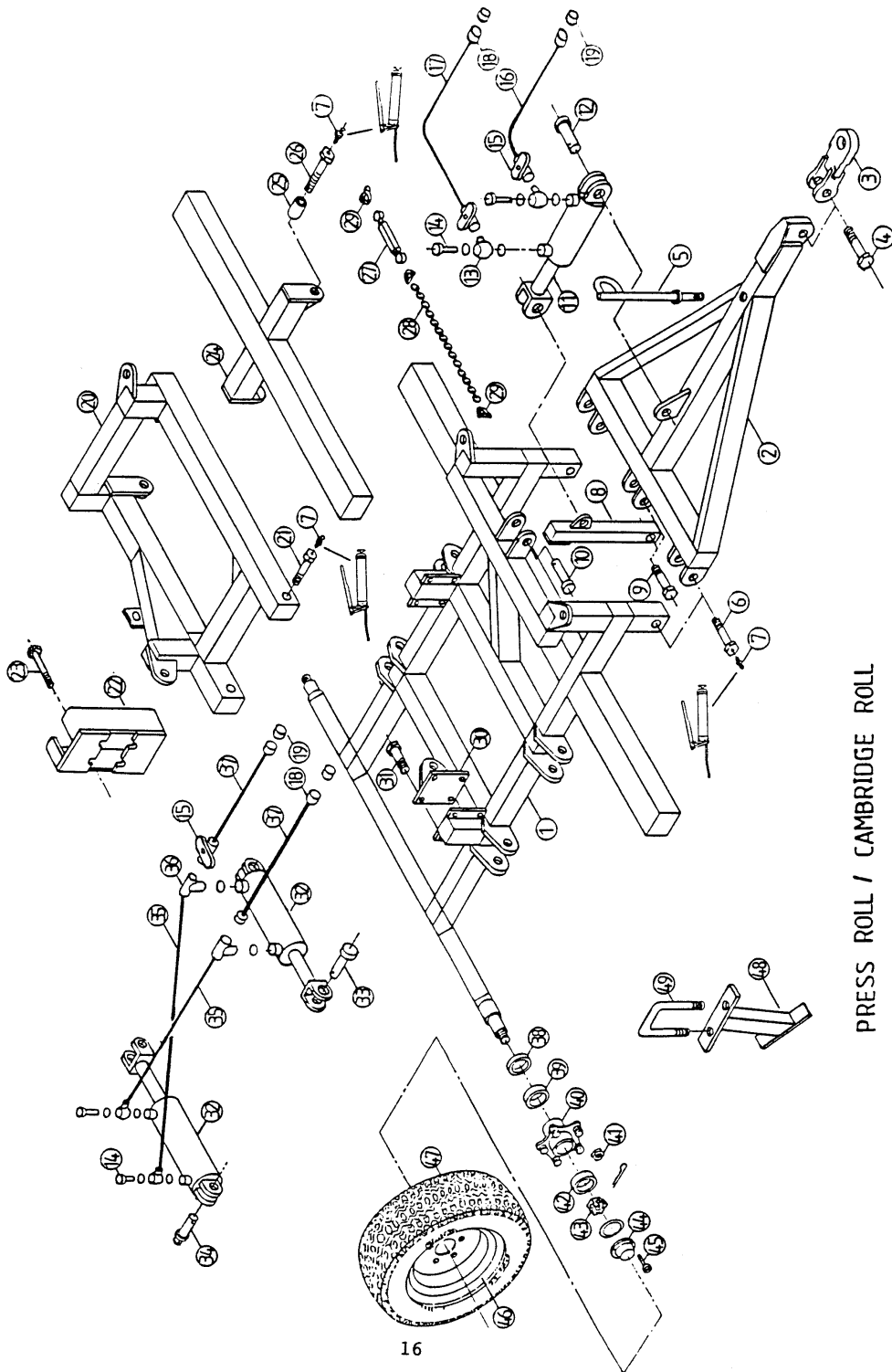

PRESS ROLL / CAMBRIDGE ROLL
 FOLDING WING SET OF THREE - MAINFRAME ASSEMBLY

PRESS ROLL / CAMBRIDGE ROLL

FOLDING WING SET OF THREE MODELS - MAINFRAME ASSEMBLY

ITEM NO.	PT.NO.	DESCRIPTION
1	2836	MAINFRAME
2	2837	DRAWBAR
3	3666B	SHACKLE - TYPE Q
4	0983	SHACKLE BOLT M30 (F/WASHER 2608, NUT 2011)
5	0985	HOSE MAST M24 (F/WASHER 2604, S/WASHER 2593, NUT 0717)
6	1720	DRAWBAR PIVOT BOLT M30 GREASABLE (F/WASHER 2608, NUT 2011)
7	0071	GREASE NIPPLE
8	2838	DRAWBAR RAM POST
9	0036	RAM POST BOLT M30 (F/WASHER 2608, NUT 2011)
10	0713	RAM POST TRANSPORT LOCKING PIN
11	0160	HYDRAULIC CYLINDER 100 X 230 D/A
	0161	CYLINDER SEAL KIT FOR 100 X 230 D/A
12	1274	CYLINDER PIN 25 X 115mm
13	0200	BANJO BLOCK
	2263	BONDED WASHER 1/2" BSP
14	0201	BANJO BOLT
15	0774	SHUT OFF VALVE
16	0183	HYDRAULIC HOSE 9ft
17	0184	HYDRAULIC HOSE 10ft
18	0203	MALE - MALE ADAPTOR
19	0205	QUICK RELEASE COUPLING
20	----	WING FRAME
21	1720	WING FRAME PIVOT BOLT M30 GREASABLE (F/WASHER 2608, NUT 2011)
22	4118	GANG PITCH CONTROL UNIT
	4119	RETAINING PLATE
23	2510	RETAINING BOLT M16 (F/WASHER 2602, NUT 2008)
24	----	WING GANG BEAM
25	2833	GANG BOX PIVOT BUSH
26	2832	GANG BOX PIVOT BOLT M30 (F/WASHER 2608, CASTLE NUT 2595, SPLIT PIN 2488)
27	1845	CHAIN TENSIONER
28	2844	WING SUPPORT CHAIN
29	2311	'D' SHACKLE
30	2842	RAM PIVOT POINT FOR 100 X 400 D/A MODELS
	2843	RAM PIVOT POINT FOR 125 X 400 D/A MODELS
31	1102	RETAINING BOLT M16 (F/WASHER 2602, S/WASHER 2038, NUT 1358)
32	0164	HYDRAULIC CYLINDER 100 X 400 D/A
	0165	CYLINDER SEAL KIT FOR 100 X 230 D/A
	1055	HYDRAULIC CYLINDER 125 X 400 D/A
	1056	CYLINDER SEAL KIT FOR 125 X 400 D/A
33	1274	PIN 25 X 115mm FOR 100 X 400 D/A CYLINDERS
	0389	PIN 30 X 125mm FOR 125 X 400 D/A CYLINDERS
34	2834	CHAIN PIN 25 X 115/50mm - 100 X 400 CYLINDERS
	2835	CHAIN PIN 30 X 125/50mm - 125 X 400 CYLINDERS
	4140	TRANSPORT CHAIN
	1040	TOPLINK

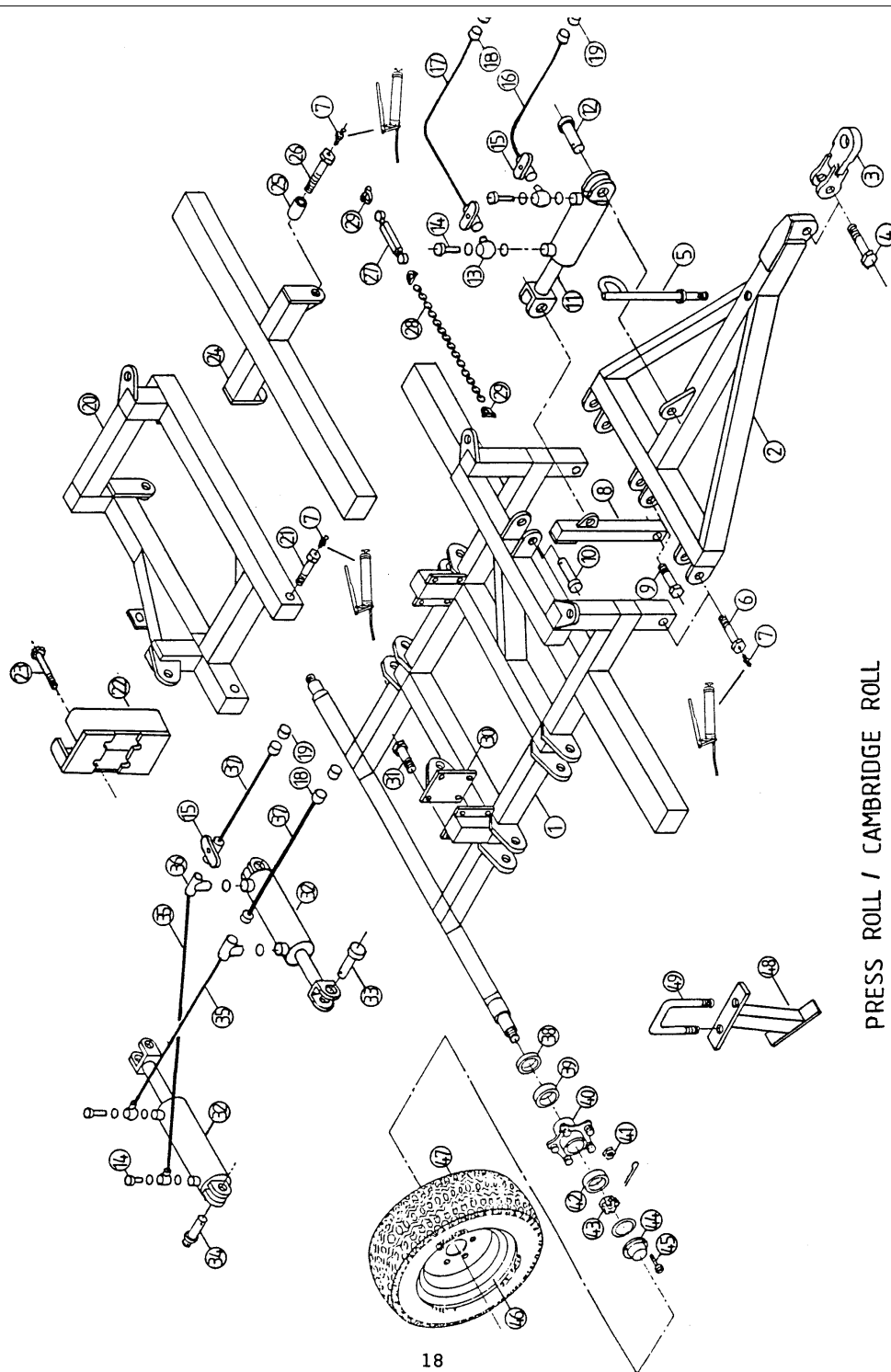

PRESS ROLL / CAMBRIDGE ROLL
FOLDING WING SET OF THREE - MAINFRAME ASSEMBLY

- 35 2307 'D' SHACKLE
- 36 0178 HYDRAULIC HOSE 4ft
- 37 0204 'T' CONNECTOR
- 0187 HYDRAULIC HOSE 13ft

5 STUD HUB MODELS

- 38 0439 GREASE SEAL
- 39 0440 INNER BEARING (CUP & CONE)
- 40 0438 HUB CASTING
- 41 0448 WHEEL NUT R/H
- 0707 WHEEL STUD R/H
- 42 0440 OUTER BEARING (CUP & CONE)
- 43 0443 CASTLE NUT (SPLIT PIN 2488)
- 44 0445 HUB CAP
- 0444 HUB CAP GASKET
- 45 0446 HUB CAP BOLT (3 PER HUB)
- 38-45 0437 5 STUD HUB COMPLETE R/H
- 46 0140 5 HOLE RIM TO SUIT 11.5/80-15 TYRE
- 47 0138 11.5/80-15, 10 PLY TYRE (TUBE 0139)

6 STUD HUB MODELS

- 38 0365 GREASE SEAL
- 39 0366 INNER BEARING CUP & CONE
- 40 0462 HUB CASTING
- 41 0471 WHEEL NUT R/H
- 0709 WHEEL STUD R/H
- 42 0367 OUTER BEARING CUP & CONE
- 43 0710 CASTLE NUT (SPLIT PIN 2488)
- 44 0370 DUST CAP
- 0739 GASKET
- 45 0469 RETAINING BOLT (3 PER HUB REQUIRED)
- 38-45 0641 6 STUD HUB COMPLETE R/H
- 46 0146 6 HOLE RIM TO SUIT 12.5/80-15 TYRE
- 47 0143 12.5/80-15, 14 PLY TYRE (TUBE 0144)
- 48 3646 PRESS ROLL BOLT ON SCRAPER (STANDARD)
- 3647 PRESS ROLL BOLT ON SCRAPER (L/H OFFSET)
- 4175 PRESS ROLL BOLT ON SCRAPER (R/H OFFSET)
- 49 1619 SCRAPER 'U' BOLT M20 (F/WASHER 2603, NUT 2009)

OPTIONAL BOLT ON REAR HITCH PLATE

- 4171 REAR HITCH PLATE
 - 4172 RETAINING PLATE
 - 1638 HITCH PLATE BOLT M20 (F/WASHER 2603, NUT 2009)
 - 2310 'D' SHACKLE
 - 4174 CHAIN
- WHEN ORDERING SPARE PARTS PLEASE QUOTE, PART NUMBER, MODEL, AND SERIAL NUMBER.

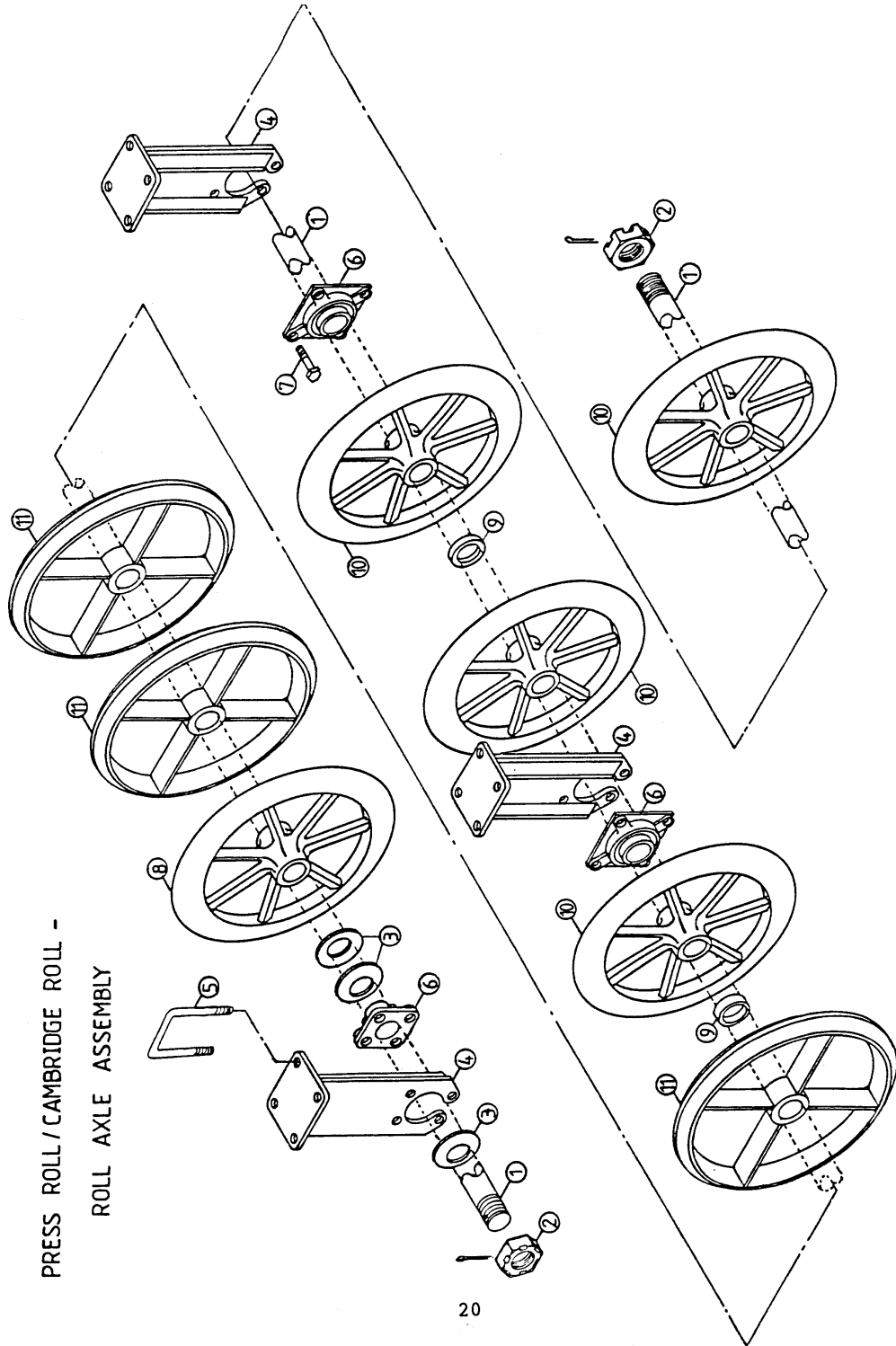

PRESS ROLL / CAMBRIDGE ROLL -
ROLL AXLE ASSEMBLY

20

PRESS ROLL / CAMBRIDGE ROLL

ROLL AXLE ASSEMBLY

<u>ITEM NO.</u>	<u>PT.NO.</u>	<u>DESCRIPTION</u>
1	----	ROLL AXLE - SEE AXLE LENGTHS AT BOTTOM OF PAGE
2	1698	AXLE CASTLE NUT M60 (SPLIT PIN 2754)
3	1514	BELLEVILLE WASHER
4	2805	BEARING PILLAR
5	1619	PILLAR 'U' BOLT M20 (F/WASHER 2603, NUT 2009)
6	1695	BEARING
7	0057	BEARING BOLT M16 (F/WASHER 2602, NUT 2008)
8	** 1515	PRESS ROLL RING 630mm - STD. 150mm BOSS WIDTH
9	2806B	SPACER - REQUIRED FOR PRESS ROLLS OF 180mm SPACING ONLY
10	** 1520	PRESS ROLL RING 630mm - MACHINED TYPE 130mm BOSS WIDTH
11	2758	CAMBRIDGE ROLL RING 630mm, 75mm WIDE, 4 SPOKE
	2807	CAMBRIDGE ROLL RING 650mm, 89mm WIDE, 5 SPOKE

**** IMPORTANT NOTE REGARDING PRESS ROLL RINGS**

IF THE RING IS **NOT** NEXT TO ANY PILLAR A STANDARD (NON-MACHINED) RING (PT.NO. 1515) WILL BE REQUIRED.

IF A BEARING PILLAR HAS A PRESS ROLL RING ON **BOTH** SIDES OF THE PILLAR THEN THESE RINGS MUST BE OF THE MACHINED BOSS TYPE (PT.NO. 1520).

IF A BEARING PILLAR IS AT THE END OF A GANG AND ONLY HAS RINGS TO THE INSIDE, OF THE PILLAR, A STANDARD (NON-MACHINED) RING (PT.NO. 1515) WILL BE REQUIRED.

<u>MACHINE</u>	<u>WIDTH</u>	<u>AXLE</u>	<u>LENGTH</u>	<u>PT.NO.</u>
ALL	ALL	CENTRE	2900	2819
PRESS C/BRIDGE	4.6M(15ft) 4.6M(15ft)	WING WING	1425 1425	2814 2814
PRESS C/BRIDGE	5.5M(18ft) 5.5M(18ft)	WING WING	1800 1900	2815 2816
PRESS C/BRIDGE	6.6M(21ft 6") 6.6M(21ft 6")	WING WING	2300 2450	2817 2818
PRESS C/BRIDGE	7.6M(25ft) 7.6M(25ft)	WING WING	2900 3000	2819 2820
PRESS C/BRIDGE	8.7M(28ft 6") 8.7M(28ft 6")	WING WING	3375 3450	2821 2822

WHEN ORDERING SPARE PARTS PLEASE QUOTE, PART NUMBER, MODEL, AND SERIAL NUMBER.

① **SIMBA**

PRESS ROLLS

② **S**

DANGER
NEVER WORK UNDER RAISED OR FOLDED
IMPLEMENTS UNLESS ALL SECTIONS
ARE SAFELY SUPPORTED.
REFER TO INSTRUCTION MANUAL
BEFORE ANY MAINTENANCE WORK.

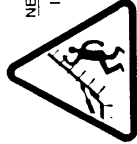

③

**PRESS ROLL
CAMBRIDGE ROLL**

④

MAINTENANCE

- DAILY SERVICE**
- 1) DO NOT GREASE ROLL AXLE BEARINGS.
 - 2) GREASE ALL PIVOT POINTS UNTIL GREASE SHOWS.
 - 3) CHECK ROLL RINGS FOR DAMAGE.
 - 4) CHECK HYDRAULIC CONNECTIONS FOR LEAKS.
- WEEKLY SERVICE**
- 1) DO NOT GREASE ROLL AXLE BEARINGS.
 - 2) TIGHTEN ALL NUTS AND BOLTS INCLUDING WHEEL NUTS.
 - 3) CHECK ROLL AXLES (SEE OPERATORS MANUAL IF LOOSE).
 - 4) CHECK TYRE PRESSURES. ADJUST IF NECESSARY.
- END OF SEASON SERVICE**
- SEE OPERATORS MANUAL FOR INSTRUCTIONS
- OPERATION**
- 1) ENSURE DRAMBAR FLOAT PINS ARE REMOVED.
 - 2) FULLY CLOSE DRAWBAR CYLINDER TO LOCK DRAWBAR.
 - 3) EXTENDING CYLINDERS UNTIL WINGS ARE PARALLEL TO MAIN FRAME.
 - 4) CLOSE WING CYLINDER TAP.

SIMBA

4147

⑤ **SIMBA**

SIMBA

Manufacturers of
Development and Earth
Moving Equipment



BRITISH MADE

Simba Machinery Ltd.

Headquarters: Road, Abingdon, Oxfordshire OX14 3TU, England.
Telephone: 01235 737111 (01235 730000)
Telex: 337314 SIMBA G

⑦

⑥ **BRITISH MANUFACTURED**



SIMBA STICKERS

ITEM NO.	PT. NO.	DESCRIPTION
1	4195	PRESS ROLL
2	2912	SIMBA "S"
	2913	SIMBA "S"
3	2918	* DANGER (RAISED SECTIONS)
4	4147	* MAINTENANCE
5	2906	SIMBA - (SMALL)
	2907	SIMBA - (MEDIUM)
	2908	SIMBA - (LARGE)
6	2911	UNION JACK (BRITISH MANUFACTURED)
7	2909	SIMBA ADDRESS

* **IMPORTANT:** ALWAYS REPLACE SAFETY AND MAINTENANCE STICKERS IF WORN.

WHEN ORDERING SPARE PARTS PLEASE QUOTE PART NUMBER, MODEL NUMBER AND SERIAL OF THE MACHINE.

