



## Disk Harrow Field Update Wing Hinge

Applies to Models: Update Kit Numbers:  
 • 3323-4336 556-196V Bolt, Lock Nut & Washers

### General Information

These instructions explain how to install the Wing Hinge Update Kit.

#### Manual Update

Refer to the Disk Harrow operator's manual for detailed information on safely operating, maintaining as it is very important to grease wing hinges. Refer to parts manual for part identification.

556-100M Operator's Manual  
 556-100P Parts Manual

#### Before You Start

For safety it is best to park machine on level concrete floor. Leave machine hooked to tractor or some kind of hydraulic source so you can raise machine up and down while you are assembling Kit. Review these instructions and make sure you understand where and how the components are installed, and which existing parts are removed or reused.

#### Tools Required

- Basic Hand Tools

### Assembly Instructions

*Refer to drawing on page 2.*

Start by unfolding the wings and removing transport lock from lift cylinders and lower the machine to the ground. **Note: Replace bolts and washers one hinge at a time. You should not slide the wing gang bar away from center gang bar.**

This is a list of the part numbers in 556-196V update kit that are used on wings and leveler assembly.

#### Part No. Description

802-822C	HHCS 1 1/2-6X13 GR5 SPTH PLT
803-350C	NUT HEX NYLOCK 1 1/2-6 PLT
804-236C	WASHER HARD 1/4 X 3 OD
802-877C	HHCS 1-8X9 GR8 SPTH PLT
803-038C	NUT HEX 1-8 NYLON INSERT PL

Remove the 1 1/2 nylock nut (1) off the 1 1/2 x 13 hex bolt (2) and remove bolt from the first hinge. Be sure to remove the two 1 1/2 flat washers from one side of the spool and wing gang tube. **Note: The old 1**

**1/2 washers are installed to the rear of the spool on the 3323-3329 and to the front of the spool on the 4330-4336 models.** You will discard the old 1 1/2 hex bolt (1), nut (2) and washer (3).

You are now ready to re-assemble this hinge. Start by sliding the two new 1 1/2 washers (4), one on the front side of spool and one on the rear of the spool. You may have to hold the washers in place while you insert the 1 1/2 x 13 special thread hex bolt (5) through the hinge assembly. Bolt must be installed so the head of the bolt is in the bolt stop as shown on page 2. Install the 1 1/2 nylock nut (6), draw nut down snug but **do not torque** to specs on this bolt as the hinge needs to move freely.

You may now install the bolts and washers one at a time on the other 3 hinges, like you did on the first hinge assembly.

After you get the four hinge bolts and washers replaced, leave the machine lowered to the ground and replace the 1 x 9 hex bolt in the leveler assembly. You may have to adjust the turnbuckle (7) or move the hydraulic level option cylinder (8), depending how your machine is equipped, to free up the 1 x 9 hex

bolt (10). Remove the 1" nylon lock nut (9) and remove 1 x 9 hex bolt (10) and discard.

Now you may install the new 1 x 9 special thread hex bolt (11) and secure with 1" nylon lock nut (12, draw nut down snug but **do not torque** to specs as the leveler needs to move freely. You may have to re level the machine as shown in the operators manual.

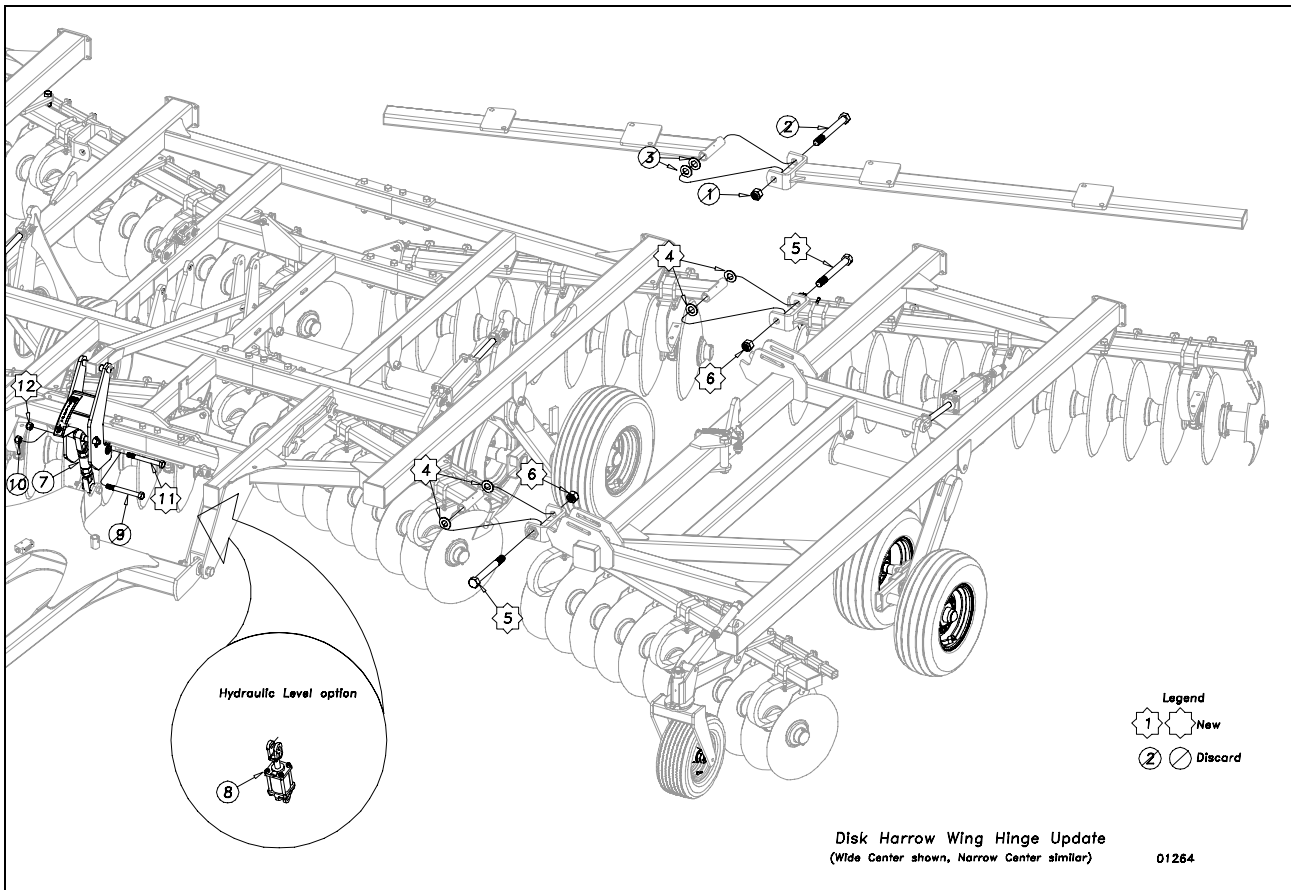

---

**Great Plains Manufacturing, Inc.**  
Corporate Office: PO. Box 5060  
Salina, Kansas 67402-5060 USA

---